



HOPEWIND



hopeSun Series
PV String Grid-Tied Inverter
(8-33KTL)

User Manual
Version: V1.4

hopeSun Series PV String Grid-Tied Inverter

(8–33KTL)

User Manual

Version: V1.4

Thank you for purchasing products developed and manufactured by Shenzhen Hopewind Electric Co., Ltd. (hereinafter referred to as “Hopewind”). We hope our products and this manual can meet your demands. Any suggestion for improvement shall be highly appreciated.

Shenzhen Hopewind Electric Co., Ltd. reserves the copyright of this manual, and it shall be subject to change without any further notice.

About This Manual



For Readers

This manual is helpful for technicians who need to install, debug, operate and maintain the string inverter of Hopewind. Please read this manual carefully before operating the product. Readers are required to know some basic knowledge about electrical components, wiring, electrical symbols and mechanical drawings.

Outlines

Chapter	Contents
1 Safety Precautions	This chapter describes the safety precautions when transporting, storing, installing, operating and maintaining the inverter.
2 Product Description	This chapter describes the basic principles, naming rules, machine configuration and product data.
3 System Installation	This chapter describes the unpacking inspection, installation tools, installation environment, reserved space, fixing method and cable connection.
4 Commissioning Guide	This chapter describes the inspection requirements before power on and how to debug and start up the inverter.
5 Maintenance and Troubleshooting	This chapter describes the daily maintenance methods, maintenance intervals and troubleshooting of the inverter.
6 Inverter Disposal	This chapter describes the basic requirements and precautions when removing, replacing, packing and disposing the inverter.

Warning Signs in This Manual

 DANGER	Major potential danger (especially refer to high voltage danger). Failure to observe the rules might cause severe personal injury or property loss.
 WARNING	Ordinary potential danger. Failure to observe the rules might cause personal injury or property loss.
 CAUTION	Ordinary potential danger. Failure to observe the rules might cause malfunction of the equipment or property loss.

Glossaries and Abbreviations

Glossaries/Abbreviations	Description
MPPT	Maximum power point tracking
PV string	Multiple solar cell arrays in parallel or series
EEPROM	Electrically erasable programmable read-only memory
hopelnsight	Hopewind background monitoring and debugging software

Contents

1 Safety Precautions	1
1.1 Transportation	1
1.2 Storage	1
1.3 Installation	2
1.4 Operation	2
1.5 Maintenance	3
2 Product Description	5
2.1 Product Introduction	5
2.1.1 Schematic Diagram	5
2.1.2 Working Mode	6
2.2 System Configuration and Networking Application	6
2.2.1 Networking Application	6
2.2.2 Supported Grid Forms	7
2.3 Naming Rules	7
2.4 Inverter Configuration	8
2.5 Package Labels	10
2.6 Enclosure Labels	10
2.7 Technical Parameters	11
2.8 Mechanical Parameters	12
2.9 Ambient Requirements	13
3 System Installation	15
3.1 Receiving Inspection	15
3.2 Preparing Installation Tools	15
3.3 Installation Environment Requirements	15
3.4 Installation Clearance Requirements	16
3.5 Installation Method	17
3.6 Electrical Connection	18
3.6.1 Cable Requirements	18
3.6.2 Cable Selection	18
3.6.3 Torque Requirements	19
3.6.4 Preparation before Operation	19
3.6.5 Connecting PE Cables	20
3.6.6 Connecting AC Output Cables	20
3.6.7 Connecting Communication Cables	21
3.6.8 Connecting DC Input Cables	22
4 Commissioning Guide	25
4.1 Checking before Power-On	25
4.2 Powering on the System	25
4.3 Powering off the System	25
5 Maintenance and Troubleshooting	27
5.1 Maintenance Items and Cycles	27
5.2 Troubleshooting	28
6 Inverter Disposal	33
6.1 Removing the Inverter	33
6.2 Replacing the Inverter	33
6.3 Packing the Inverter	33
6.4 Disposing of the Inverter	33

1 Safety Precautions

This chapter describes the safety precautions that must be observed when installing, operating and maintaining the inverter. Please read them carefully before operation and follow them in operation process; otherwise it might cause damage to the inverter, the generator and related equipment or cause serious injury or loss of life.

When you use and operate the inverter, please take special attention to:



1. Only the qualified personnel are allowed to install, operate and maintain the inverters.
2. Do not incline or collide the product in transportation.
3. Do not make any liquid, sundries or rubbishes enter inside as they might cause short circuit inside the inverter.
4. Inverter must be disconnected with AC grid before completion of installation and maintenance.
5. Related protective measures are required to avoid electric shock or fire accident.



Please do not place inflammables and explosives around the inverter to ensure environmental safety.

1.1 Transportation



1. When transporting, it is necessary to ensure that the inverter is packaged properly and the cabinet is fixed upwards to avoid strong vibration and collision.
2. In order to keep the inverter in good condition during transportation, it must be transported with packaging and operated according to the labels on the package. For the meaning of the labels, please refer to **2.5 Package Labels**.
3. The transportation environment must meet the requirements. Please refer to **2.9 Ambient Requirements**.

1.2 Storage



The storage environment of the string inverter must meet the corresponding requirements. Please refer to **2.9 Ambient Requirements**.

About long-term storage:

Before or after the installation and commissioning, if the string inverter is in the no-power supply state for more than three weeks, it is regarded as long-term storage. Long-term storage of string inverters requires attention to the following issues:

- Put the desiccant into the cabinet and package the whole machine with packaging materials.
- When storing equipment, pay attention to ventilation and moisture. Stagnant water is strictly forbidden in the storage environment.
- Pay attention to the harsh environment, such as quenching, sudden heat, collision, dust, etc., to avoid



damage to the string inverter.

- Regular inspections are required, usually not less than once a week. Check whether the packaging is intact to avoid pest bites. If it is damaged, it needs to be replaced immediately.
- If the storage time exceeds half a year, the package should be opened for inspection, repackaged, and desiccant replaced.
- It is strictly forbidden to store the device without packaging.

1.3 Installation



1. Before operating the internals of the string inverter, it must be confirmed that the DC switch of the string inverter and the circuit breaker corresponding to the AC side of the inverter are in the off state, and the housing of the inverter is reliably grounded.
2. The string inverter must be grounded according to the specifications. The size of the grounding conductor must meet the requirements of safety regulations to ensure the safety of personnel.



1. During installation, it is necessary to ensure that the string inverter's installation environment is well ventilated and heat-dissipating, and the device should not be directly exposed to sunlight.
2. The fixing of the string inverter is recommended by two people working together to avoid mechanical damage. During the installation process, safety measures should be taken to prevent bruises.
3. During installation and maintenance, it is necessary to prevent liquid, dust or debris from entering the inside of the string inverter. Conductive liquids and debris may cause internal short circuit of the string inverter, resulting in equipment damage.
4. When connecting the wiring of the external cable to the string inverter, the installation torque of the power cable must be ensured. Excessive torque may cause fatigue damage of the screw while too small torque may cause the contact resistance to become large, resulting in overheating.
5. The power cable terminals connected to the string inverter must comply with national standards. If the terminals are not in accordance with the standards, the power cable may be overheated. In severe cases, a fire may occur.
6. The installation site must meet the requirements of the operating environment. Please refer to **2.9 Ambient Requirements**.

1.4 Operation



1. During the operation of the string inverter, it is necessary to ensure that the door panel of the string inverter is locked to prevent personal injury such as electric shock, and to prevent salt, moisture, dust or other conductive substances in the air from entering the string inverter.
2. When the string inverter is powered on, it is prohibited to touch the internal single boards, devices, cables and terminals of the string inverter and to plug and unplug the external terminals.
3. In case of any fault, abnormal smell or sound of the string inverter, please immediately switch off the DC switch of the string inverter and the circuit breaker on the AC side of the inverter.



1. Power on the string inverter only after all installation work is completed and cables are connected correctly.
2. It is prohibited to conduct any insulation resistance test or voltage withstand test on the string inverter. Wrong voltage withstand test will damage the string inverter.
3. When conducting insulation withstand voltage test on external equipment of the string inverter, the wiring between the string inverter and the external equipment must be disconnected.

1.5 Maintenance



1. Before maintenance work, you must first disconnect the AC output side circuit breaker, then disconnect the DC switch, and wait at least 5 minutes before operating the string inverter.
2. During the maintenance process, try to avoid irrelevant personnel from entering the maintenance site.
3. Please maintain the string inverter under the condition that you are familiar with the contents of this manual and have suitable tools and test equipment.
4. For personal safety, please wear insulating gloves and anti-smashing shoes.



The string inverter must be checked and maintained regularly. For details, please refer to **5 Maintenance and Troubleshooting**.

--End of the chapter--

2 Product Description

2.1 Product Introduction

The hopeSun series three-phase string inverters are independently developed by Hopewind, whose main function is to convert the DC power generated by the PV string into AC power and feed it into the power grid.

The hopeSun 8KTL/10KTL/12KTL have 2 input interfaces, hopeSun 15KTL/17KTL have 3 input interfaces, hopeSun 20KTL/22KTL/25KTL have 4 input interfaces, and hopeSun 30KTL/33KTL have 6 input interfaces. They are only suitable for 400VAC low-voltage grid-connected scenarios, such as village-level photovoltaic power stations below 400kW or industrial and commercial rooftop photovoltaic power stations.

2.1.1 Schematic Diagram

The hopeSun 8KTL/10KTL/12KTL access 2 PV strings, hopeSun 15KTL/17KTL access 3 PV strings, hopeSun 20KTL/22KTL/25KTL access 4 PV strings, and hopeSun 30KTL/33KTL access 6 PV strings. There are 2 MPPT circuits inside the inverter to track the MPPT of the strings, and then convert the DC power to three-phase AC power through the inverter circuit. The schematic diagram is shown below.

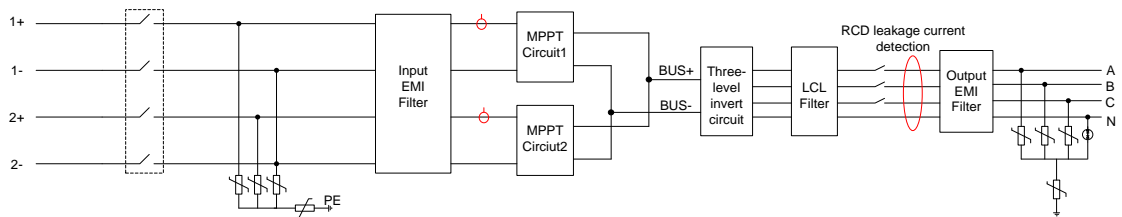

Figure 2-1 System schematic diagram of inverters with 2 inputs

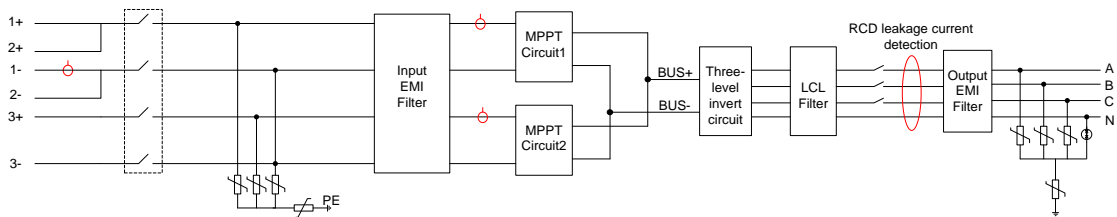

Figure 2-2 System schematic diagram of inverters with 3 inputs

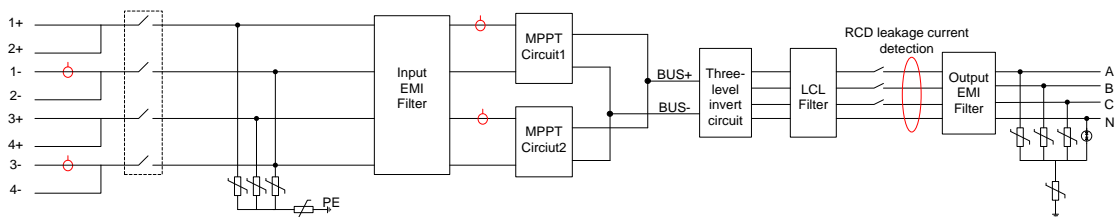

Figure 2-3 System schematic diagram of inverters with 4 inputs

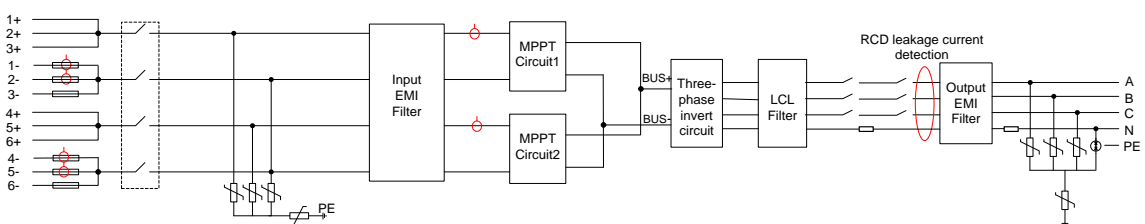

Figure 2-4 System schematic diagram of inverters with 6 inputs

2.1.2 Working Mode

The hopeSun three-phase string inverter has three working modes: standby mode, operating mode, and shutdown mode. The switching conditions of the three modes are shown as follows.

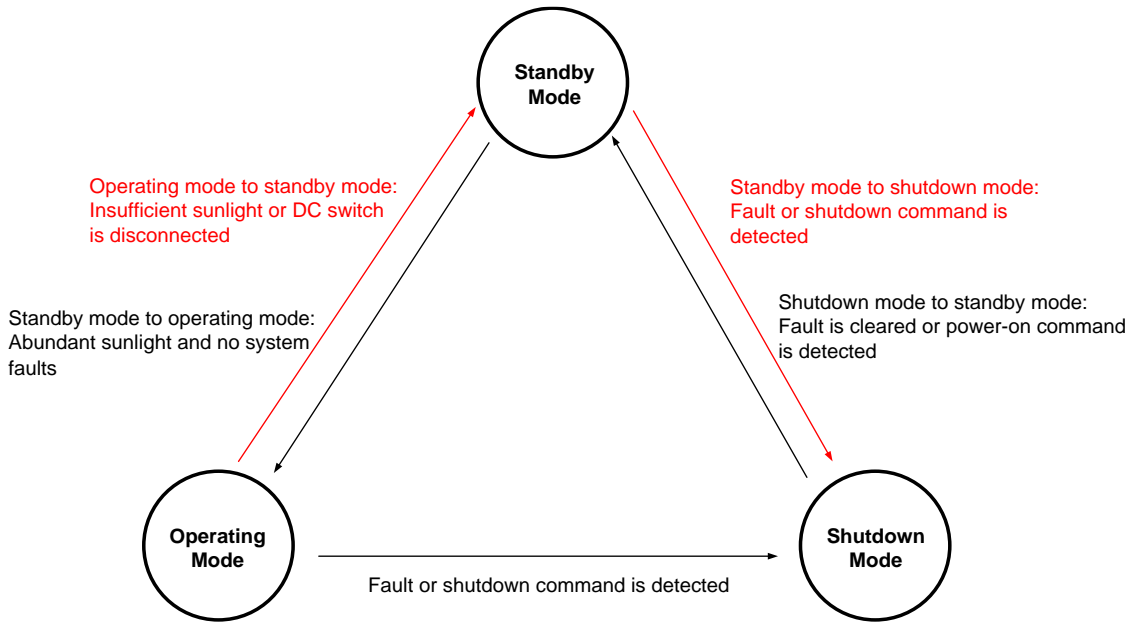

Figure 2-5 Working mode

Working mode	Description
Standby	1) Standby mode mainly means that the external environment does not meet the operating conditions of the inverter such as insufficient sunlight and the disconnection of DC input switch. In this mode, the inverter continuously self-tests and enters the operating mode once the operating conditions are met. 2) In the standby mode, if the inverter detects a shutdown command or finds a fault after the power-on test, it enters the shutdown mode.
Operating	In the operating mode, the inverter converts the DC power of the PV string into AC power and feeds it into the grid. The inverter performs MPPT operation to make the PV string output maximum power. If the inverter detects a fault or a shutdown command, it enters the shutdown mode. If it is detected that the input power of the PV string is lower than the grid-connected power generation condition, it enters the standby mode.
Shutdown	If the inverter detects a fault or a shutdown command during standby or operation, it switches to the shutdown mode. In the shutdown mode, if the inverter detects that the fault has been cleared or a power-on command, it enters the standby mode.

2.2 System Configuration and Networking Application

2.2.1 Networking Application

Figure 2-6 shows the networking application of the string inverter, and Figure 2-7 shows the networking design scheme of the distributed PV power station.

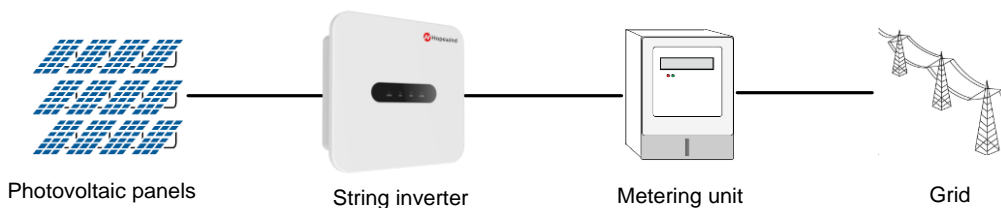

Figure 2-6 Networking application schematic diagram of string inverter

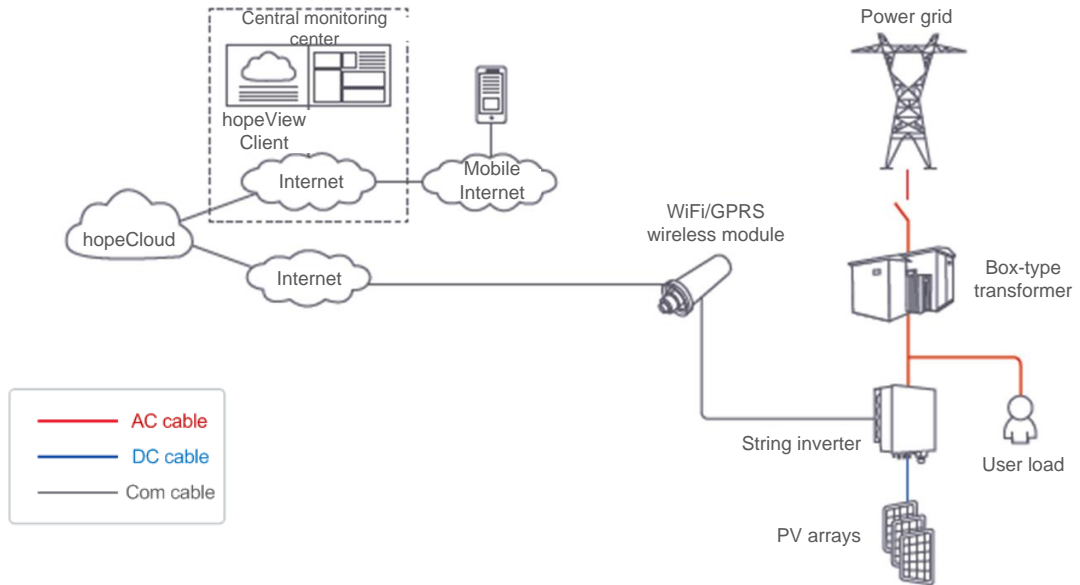

Figure 2-7 Networking scheme of distributed PV power station

2.2.2 Supported Grid Forms

The power grid forms supported by hopeSun 8KTL~hopeSun 33KTL include TN-S, TN-C, TN-C-S, TT and IT.

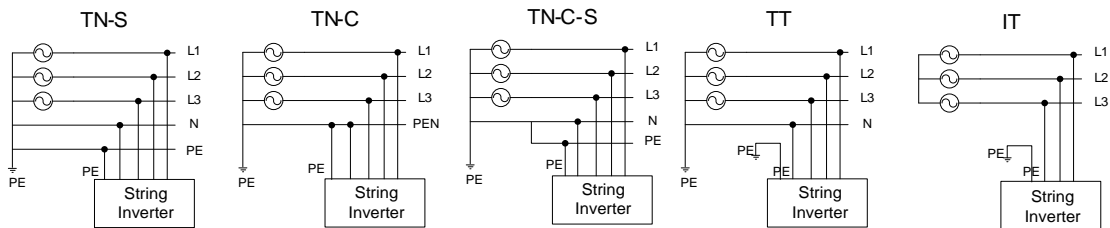

Figure 2-8 Schematic diagram of various power grid forms

2.3 Naming Rules

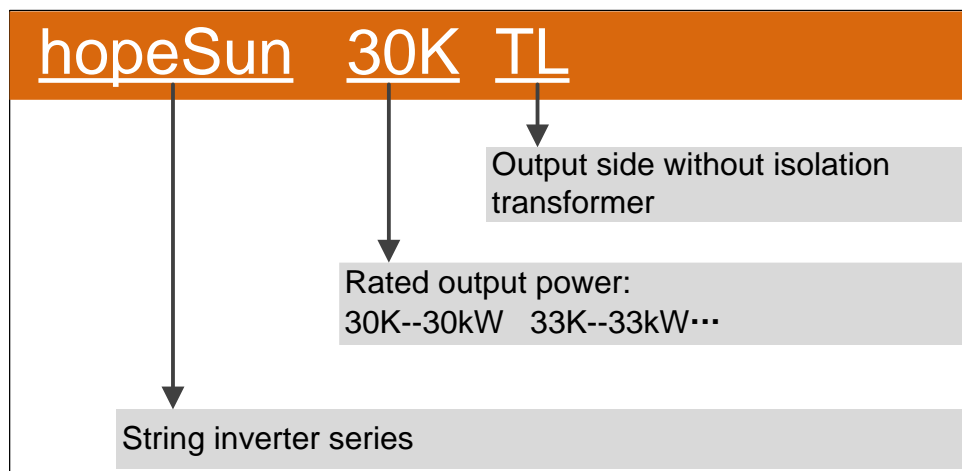

Figure 2-9 Naming rules

2.4 Inverter Configuration

This section describes the internal components, back components and bottom interfaces of the string inverter. The bottom structure of different models may be different, and the model of 30KTL is taken as an example here.

 CAUTION		
<p>There are components on the board that are very sensitive to static electricity. Anti-static measures must be taken before touching the board.</p> <p>When touching the board, be careful not to scratch the electrical components.</p>		
		
No.	Label	Device name
1		Door panel
2		LED indicator

Figure 2-10 Front view of the inverter

The LED indicators from left to right are described as follows:

Table 2-1 LED Indicator Description

Indicator light	Meaning	Status	Description
	PV and grid connection	Blue light on	The PV side and the grid are connected normally
		Blue light fast blinking	The grid is connected normally but the PV side is connected abnormally
		Blue light slow blinking	The PV side is connected normally but the grid is not connected
		Blue light off	Both the PV side and the grid are not connected
	Grid-connected operation	Blue light on	The inverter is in grid-connected power-on state
		Blue light off	The inverter is neither grid-connected nor powered on
	Communication indication	Blue light fast blinking	Communication normal
		Blue light off	Communication abnormal
	Alarm indication	Red light blinking	Alarm
		Red light solid on	Fault

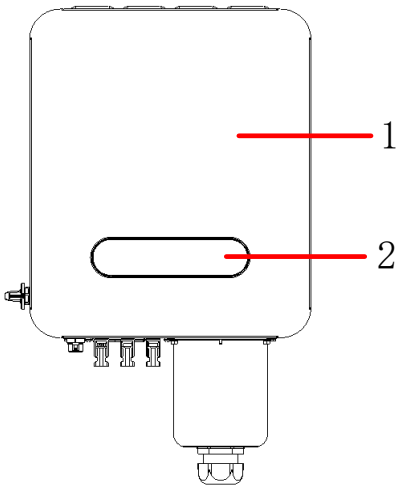
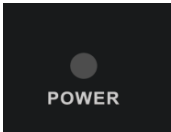
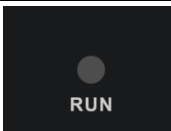
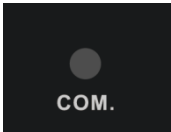
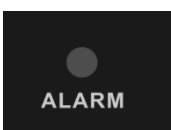
Remarks:

Slow blinking: 1 second on and 2 seconds off in cycles;

Fast blinking: 0.5 seconds on and 0.5 seconds off in cycles.

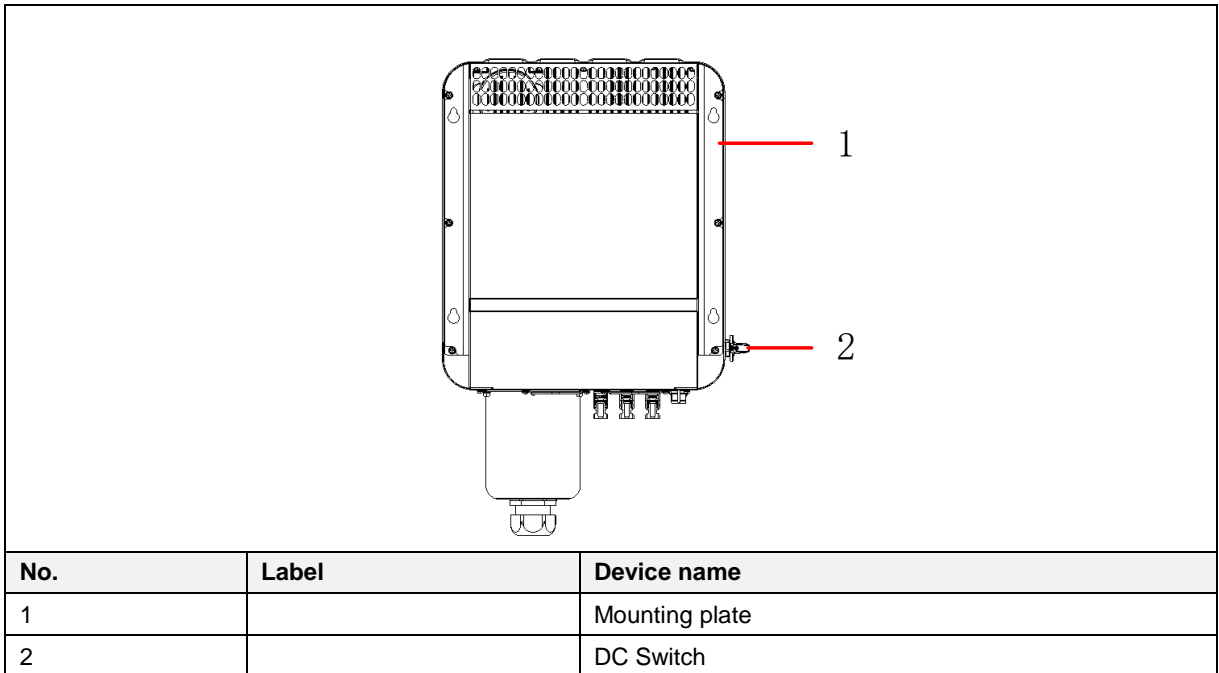

Figure 2-11 Back view of the inverter

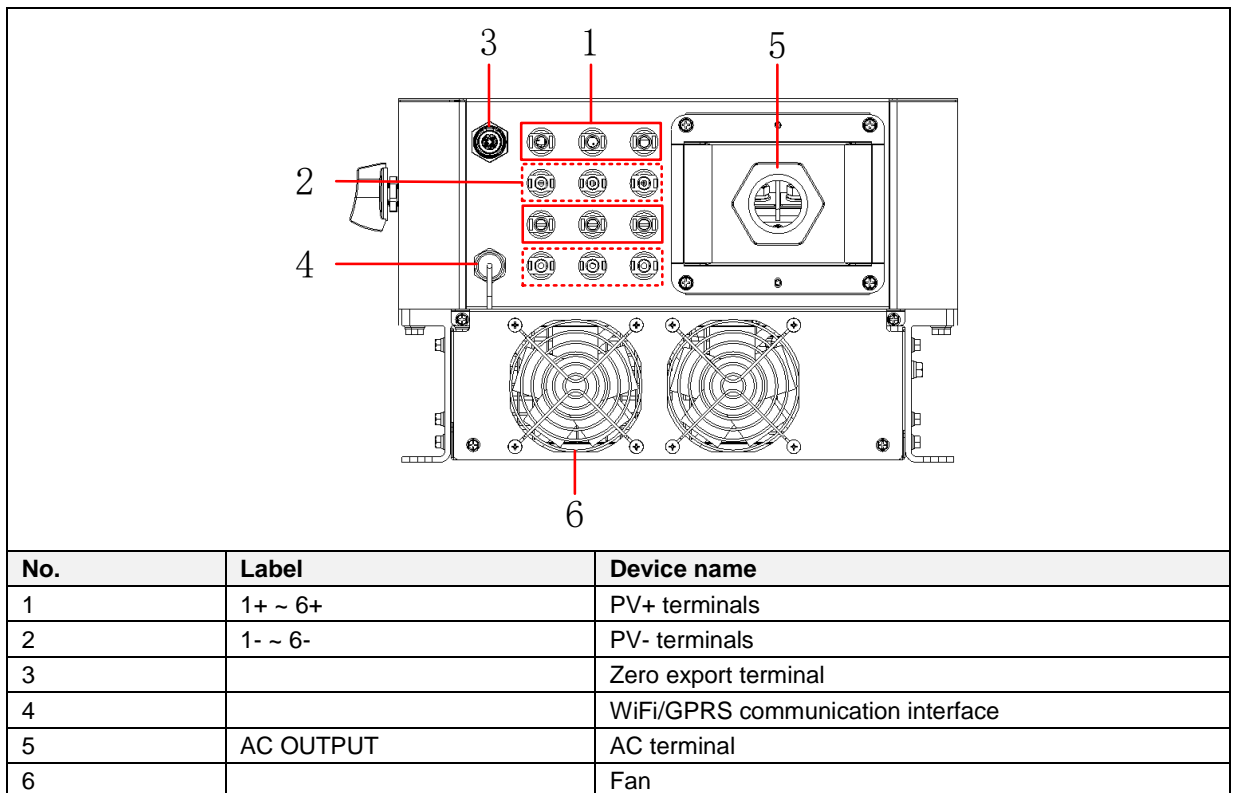



Figure 2-12 Bottom view of the inverter

 Note: hopeSun 8KTL/10KTL/12KTL have only 2 PV string inputs at the bottom, hopeSun 15KTL/17KTL have 3 inputs, hopeSun 20KTL/22KTL/25KTL have 4 inputs, and hopeSun 30KTL/33KTL have 6 inputs. Models below 15kW have no cooling fan at the bottom.

2.5 Package Labels

On the outer packaging of the product, there are some labels to guide the user to transport and store the product. The meanings indicated by the labels are as follows:

	No stacking		Handle with care. Avoid damage to the converter caused by intense collision and friction in the process of transportation and movement.
	No stepping		Keep dry. Prevent the inverter from getting wet or damp
	Place vertically and no tilting		No rollover
FRONT 机柜正面	Front side of the product	BACK 机柜背面	Back side of the product

2.6 Enclosure Labels

In order to ensure the personal and property safety of users when using this product and avoid accidents, the following warning labels may be placed inside and outside the string inverter to remind users of safety precautions during operation.

	PE: Grounding point indicating the position for connecting the PE cable.
	Warning: Ordinary potential hazard. Failure to observe the rules might cause personal injury or property loss.
	Danger: High voltage hazard. Failure to observe the rules might cause serious personal injury or property loss.
	Hot surface sign: Pay attention to the hot surface to prevent being burnt.
	Refer to the user manual: Please refer to the user manual for detailed instructions.
	Discharge sign: Do not touch the live parts until 5 minutes after disconnection from the power source to prevent electric shock.

2.7 Technical Parameters

	Model	hopeSun 8KTL	hopeSun 10KTL	hopeSun 12KTL	hopeSun 15KTL	hopeSun 17KTL
DC parameters	Maximum DC voltage	1100V				
	Startup voltage	180V				
	MPPT voltage range	200V~1000V				
	MPPT full load working voltage range	370V~850V			450V~850V	
	Maximum input current per MPPT	20A/20A			26A/20A	
	Maximum input path	2			3	
	Number of MPPT	2				
AC parameters	Rated output power	8kW	10kW	12kW	15kW	17kW
	Maximum active power	8.8kW	11kW	13.2kW	16.5kW	18.7kW
	Rated grid voltage	400VAC				
	Allowable voltage range	300VAC~520VAC				
	Rated output current	11.6A	14.5A	17.4A	21.7A	24.6A
	Maximum output current	12.7A	16A	19.1A	23.9A	27A
	Rated grid frequency	50Hz/60Hz				
	Power factor	-0.8~+0.8				
	Total harmonic distortion of current	<3%				
System parameters	Maximum efficiency	98.60%				
	European efficiency	98.10%				
	Insulation impedance test	Supported				
	Residual leakage current detection	Supported				
	String fault detection	Supported				
	Output overcurrent protection	Supported				
	Protection grade	IP65				
	Type of cooling	Natural cooling			Smart air cooling	
	Night consumption	<1W				
	Display	LED; WLAN+ APP				
	Communication interface	WIFI, zero export				
	DC terminal	MC4 plug-in terminal				
	AC terminal	SC terminal & cable gland				

	Model	hopeSun 20KTL	hopeSun 22KTL	hopeSun 25KTL	hopeSun 30KTL	hopeSun 33KTL
DC parameters	Maximum DC voltage	1100V				
	Startup voltage	180V				
	MPPT voltage range	200V~1000V				
	MPPT full load working voltage range	425V~850V				
	Maximum input current per MPPT	30A/30A			40A/40A	
	Maximum input path	4			6	
	Number of MPPT	2				
AC parameters	Rated output power	20kW	22kW	25kW	30kW	33kW
	Maximum active power	22kW	24.2kW	27.5kW	33kW	36.3kW
	Rated grid voltage	400VAC				
	Allowable voltage range	300VAC~520VAC				
	Rated output current	28.9A	31.8A	36.1A	43.5A	47.6A
	Maximum output current	31.8A	35A	39.7A	47.8A	52.4A
	Rated grid frequency	50Hz/60Hz				
	Power factor	-0.8~+0.8				
	Total harmonic distortion of current	<3%				
System parameters	Maximum efficiency	98.60%				
	European efficiency	98.10%		98.30%		
	Insulation impedance test	Supported				
	Residual leakage current detection	Supported				
	String fault detection	Supported				
	Output overcurrent protection	Supported				
	Protection grade	IP65				
	Type of cooling	Smart air cooling				
	Night Consumption	<1W				
	Display	LED indicators + APP				
	Communication interface	WIFI, zero export				
	DC terminal	MC4 plug-in terminal				
	AC terminal	Tube terminal		OT/DT terminal & Cable gland		

2.8 Mechanical Parameters

➤ Dimension and Weight

Model	W*H*D (mm)	Net weight (kg)
hopeSun 8KTL	360*400*247	≤22
hopeSun 10KTL		
hopeSun 12KTL		
hopeSun 15KTL		
hopeSun 17KTL		
hopeSun 20KTL	380*450*247	≤25
hopeSun 22KTL		
hopeSun 25KTL		≤30
hopeSun 30KTL		
hopeSun 33KTL		≤35

 Note: Dimension of the inverter here does not contain hangers, handles, pads and other components. Dimension error: ±10mm.

➤ Dimension of the Inverter and Mounting Plate

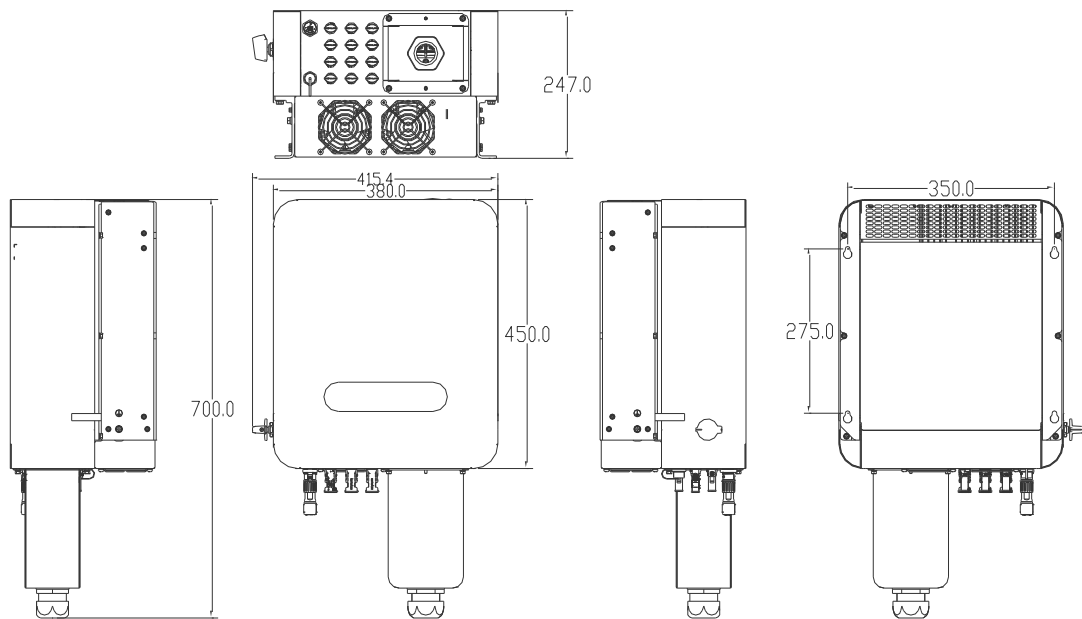

Figure 2-13 Dimensions of the inverter (unit: mm)

📖 Note: The model shown in the picture below is 30KTL. The inverter sizes of other models are similar, but the size of AC cable protection cover may be different.

2.9 Ambient Requirements

Transportation environment	Requirements	
Type of shipping	Waterways, railways, highways, aviation, etc.	
Ambient temperature	-40°C~+70°C	
Relative humidity	≤95% when the temperature is +40°C	
Mechanical condition	The vibration should not exceed the following limits: 2Hz≤f<9Hz, displacement 7.5mm; 9Hz≤f<200Hz, acceleration 20m/s ² ; 200Hz≤f<500Hz, acceleration 40m/s ²	
Storage environment	Requirements	
Storage place	Store the product in a warehouse with air circulation, no harmful gases, no flammable or explosive materials, and no corrosive materials. Avoid strong mechanical vibrations and shocks and stay away from strong magnetic fields.	
Ambient temperature	-40°C~+70°C	
Relative humidity	≤95%	
Mechanical condition	The vibration should not exceed the following limits: 10Hz≤f<57Hz, displacement 0.075mm; 57Hz≤f<150Hz, acceleration 10m/s ²	
Working environment	Requirements	
	Normal operation state	Shutdown state
Installation place	Do not install the inverter in an area where flammable or explosive materials are stored. The installation site can be indoors or outdoors, preferably in a well ventilated environment. Avoid direct sunlight, rain and snow to extend the life of the inverter. It is recommended to install it in a sheltered location. If it is not possible, install an awning.	
Ambient temperature	-40°C~+60°C (Derating is required while the temperature is above 45 °C)	-40°C~+70°C
Relative humidity	Relative humidity: 0%~100%, internal condensation is not allowed.	

User Manual

Altitude	≤4000m; derating is required when the altitude is above 3000m.
Mechanical condition	The vibration should not exceed the following limits: 10Hz≤f<57Hz, displacement 0.075mm; 57Hz≤f<150Hz, acceleration 10m/s ² .

--End of the chapter--

3 System Installation

3.1 Receiving Inspection

After confirming that the outer packaging is intact, please carry out the unpacking inspection. Unpack the packaging box and check whether the appearance of the string inverter is in good condition. When opening the package, please use tools carefully to avoid scratching the string inverter.

Although the inverter has been strictly tested and inspected before leaving factory, accidental damage might happen during transportation. Please inspect and check the product as soon as you receive it. If there is any damage or omission, please contact us and we will help you as soon as possible.

3.2 Preparing Installation Tools

Tool or device	Purpose	Remarks
4#Inner hexagon spanner	Disassemble and assemble of the lower door panel of the inverter	
Phillips screwdriver (PH2)	Fasten the grounding screws and screws of mounting plates	Bolt specifications: M6 and M8
Tube type crimping pliers	Crimp the communication cable terminals	
Socket wrench	Wire the output cable	Bolt specifications: M8
MC4 crimping pliers	Crimp the MC4 terminals	The input cable needs to be crimped into the MC4 terminal before it can be connected to the PV+/PV- terminal on the inverter
MC4 removal tool	Remove MC4 terminal	
Wire stripper	Strip wire	
Multimeter	Measure voltage to ensure wiring and installation safety	
Safety equipment	Necessary labor protection	Insulating shoes, gloves, etc

3.3 Installation Environment Requirements

- The environmental requirements for the installation of string inverter are described in "**1 Safety Precautions**".
- The installation method and position must be suitable for the weight and dimension of the string inverter. See "**2.8 Mechanical Parameters**".
- The string inverter should be installed in a well ventilated environment for heat dissipation. As direct sunlight, rain and snow shortens the life of the inverter, it is recommended to choose sheltered installation sites. If that cannot be satisfied, please set up a sun shading shelter (optional accessory).
- During the operation of the string inverter, the temperature of the chassis and the radiator will be relatively high. Do not install the inverter in the position which will be touched unintentionally.

 Note: This chapter takes hopeSun 30KTL as an example to introduce the cable connection methods for installation. The interfaces of other models may be different, so please connect cables according to actual situation while referring to this chapter.

3.4 Installation Clearance Requirements

When installing the string inverter, suitable space must be reserved around it for heat dissipation and maintenance.

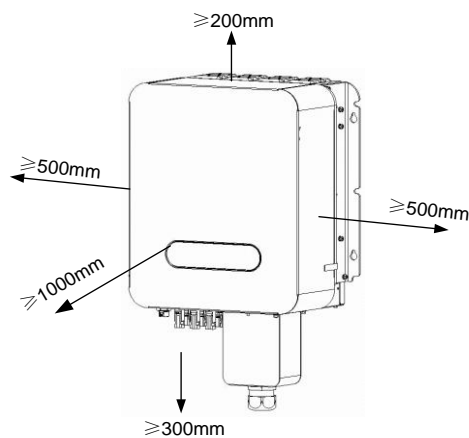

Figure 3-1 Reserved space requirements

If multiple inverters are installed at the same height, the horizontal installation is recommended.

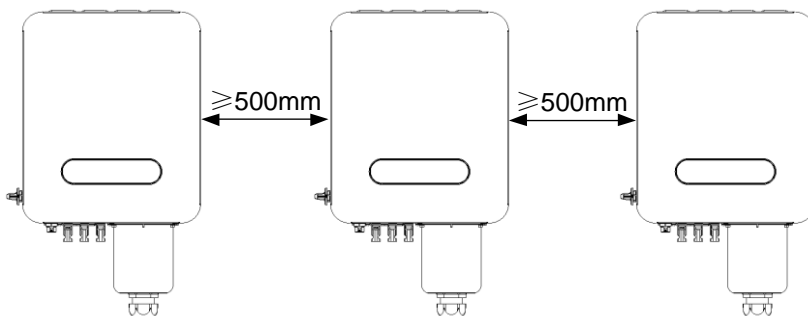

Figure 3-2 Horizontal installation mode

If multiple inverters are required to install in two rows, the triangle installation is recommended.

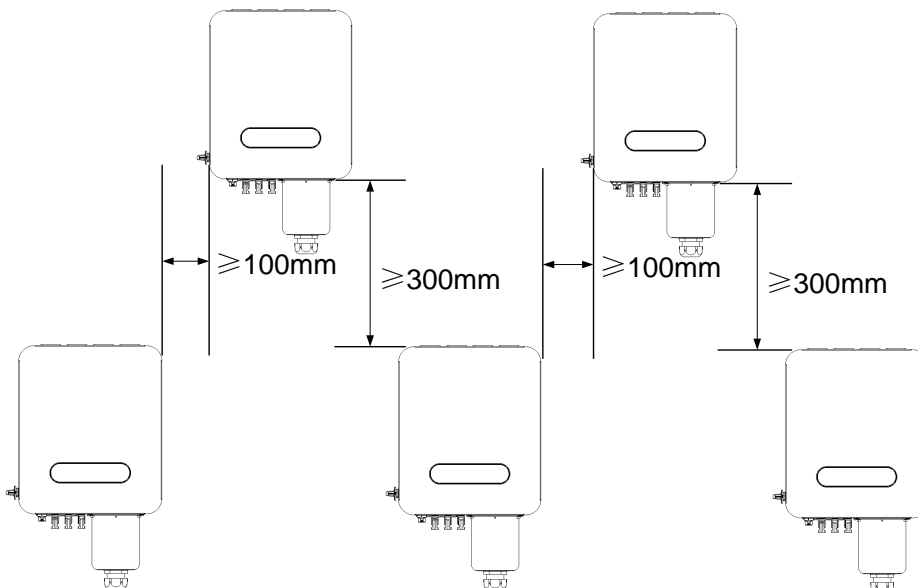

Figure 3-3 Triangle installation mode

3.5 Installation Method



1. Please refer to **1 Safety Precautions** for precautions during inverter installation. For installation environment requirements, please refer to **3.3 Installation Environment Requirements**.
2. During installation, it must be confirmed that the site installation position can bear the total weight of the inverter and accessories to avoid falling during installation or use.
3. It is recommended that two people work together to fix the inverter to avoid mechanical injury. During installation, safety measures shall be taken to prevent injuries.
4. Please install it vertically or tilt it back 15 ° at most to facilitate heat dissipation of the machine. Do not tilt the inverter (tilt forward, tilt back too much, roll), horizontally or upside down.
5. If it is impossible to avoid direct sunlight, please add a sunscreen.

➤ Installation steps

Before installing the inverter, check whether the delivery is complete. There should be: the inverter*1; accessories*1 set; AC wiring cover*1; mounting plate*1.

1. Take out the mounting plate and the mounting bracket.

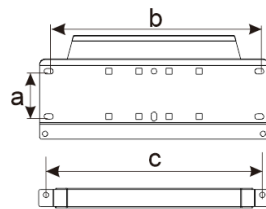

Power Range	a	b	c
8~17kW	50mm	306mm	335mm
20~33kW	75mm	350mm	350mm

2. Install the mounting bracket to the inverter.

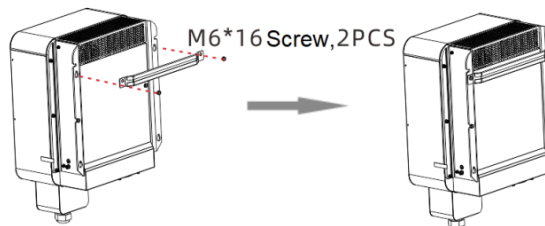

3. Install the mounting plate to the wall or the bracket.

Drill holes on the wall (diameter:
10mm; depth: 80mm)

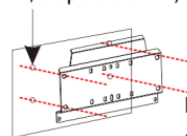

Wall mounting

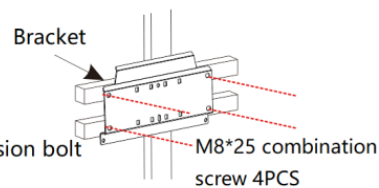

Bracket mounting

4. Hang the mounting bracket of the inverter to the mounting plate and fix it with screws to prevent it from shaking.

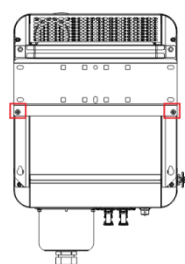
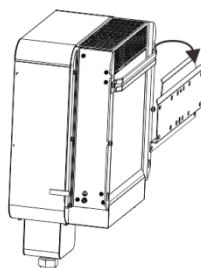

3.6 Electrical Connection

3.6.1 Cable Requirements

The choice of cable should comply with relevant national standards and meet the load requirements.

Power cable requirements

Please refer to the electrical data of the product, and then comprehensively consider the ambient temperature, current, margin as well as other relevant factors to select the cable.

Communication cable requirements

Since weak communication signals are susceptible to external interference, it is necessary to adopt communication cables with shielding layers, and the shielding layer should be grounded reliably. You can refer to the relevant document of *GB 50217-2007 Code for Design of Cables of Electric Engineering*.

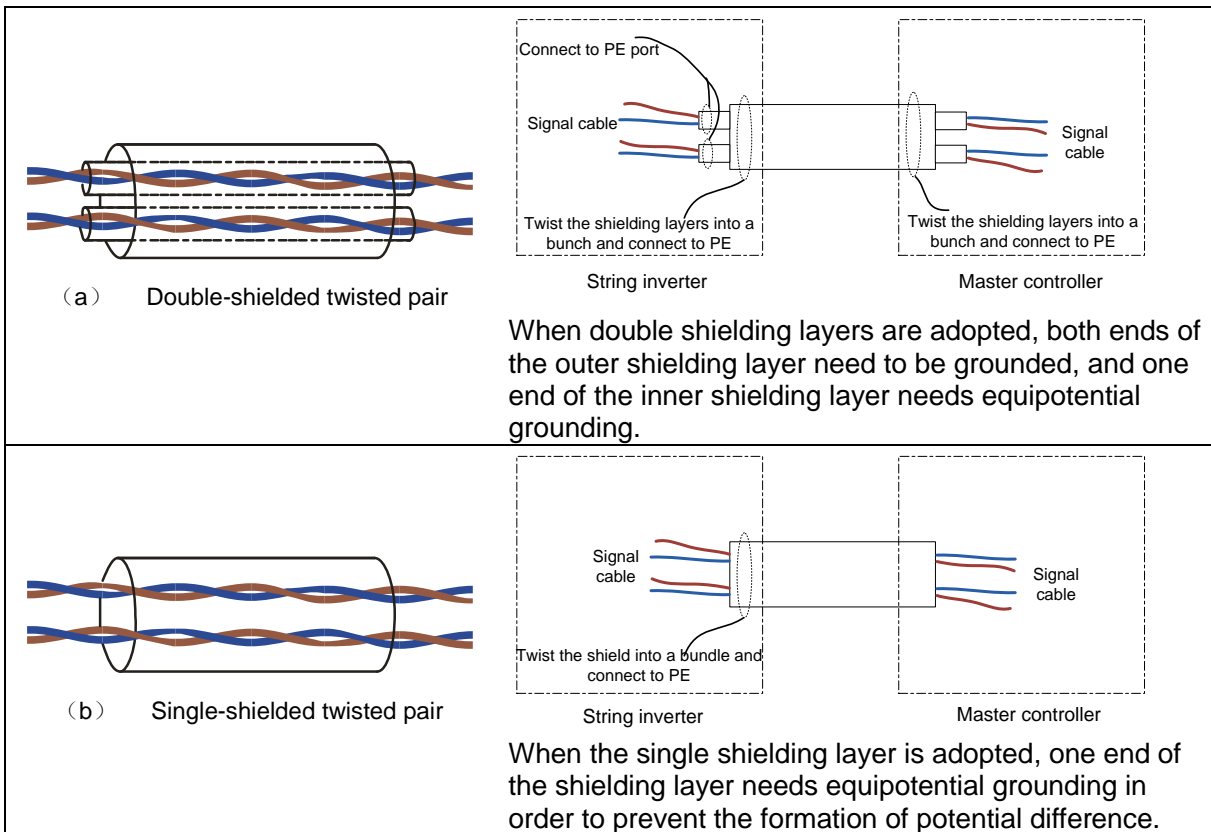

Figure 3-4 Twisted pair with shielding layer

3.6.2 Cable Selection

Name	Recommended Cable Specifications		
PV DC branch cable	Industry general PV cable, model: PV1-F It is recommended to use copper cables with the cross-sectional area of 4.0mm ² -6.0mm ² for each PV+ and PV- branch.		
AC side cable	Model	Recommended cross-sectional area of the 4-core copper cable (S)	Recommended cross-sectional area of the 4-core aluminum cable
	8-12kW	10~16mm ²	/
	15-17kW	10~16mm ²	/
	20-22kW	16~25mm ²	/
	25-33kW	25~50mm ²	35~50mm ²
PE cable	Recommended cross-sectional area of the cable: Products with power of 8~17kW: not less than 16mm ²		

Name	Recommended Cable Specifications			
	Products with power of 20~33kW: not less than the maximum between S/2 and 16mm ²			
AC side terminal type and suitable wire size	Model	AC output terminal type	Outer diameter of the AC cable, mm (including insulation skin)	Width of the AC terminal
	8-12kW	SC	$13 \leq \phi \leq 20$	$\leq 12.5\text{mm}$
	15-17kW	SC	$13 \leq \phi \leq 20$	$\leq 12.5\text{mm}$
	20-22kW	Tube terminal	$18 \leq \phi \leq 25$	/
	25-33kW	DT/OT	$22 \leq \phi \leq 32$	$\leq 23.5\text{mm}$

3.6.3 Torque Requirements

When tightening cable connections, the tightening torque needs to meet the requirements of the following table.

Table 3-1 Torque requirements for cable connection

Thread specification	Performance level 4.8		Performance level 8.8		Unit
	General Connection	High tightness connection	General Connection	High tightness connection	
M3	6	8			kgf.cm
M4	12	14			kgf.cm
M5	25	30			kgf.cm
M6	50	60			kgf.cm
M8			110	150	kgf.cm
M10			300	390	kgf.cm
M12			550	650	kgf.cm
M16			1600	2000	kgf.cm

 Note: Inside the string inverter, the bolts with the nominal diameter of the external thread above 8mm are 8.8 Dacromet bolts.

3.6.4 Preparation before Operation

 DANGER	
1.	When connecting cables, do not operate when the product is energized and please follow the relevant requirements in 1 Safety Precautions .
2.	Before connecting the cables, please complete the following preparations to avoid personal injury. <ol style="list-style-type: none"> 1) Before electrical connections, please make sure that the "DC SWITCH" of the inverter is in the "OFF" state, otherwise the high voltage of the inverter may cause a shock hazard. 2) Determine the positive and negative poles of the input cable and mark them, and make sure that the input cable is disconnected from the PV string. 3) Please confirm that the open circuit voltage of the PV string does not exceed the specified limit.
3.	When connecting DC input cables, please make sure that the positive and negative poles of the DC input cables correspond to those of the inverter PV terminals.

3.6.5 Connecting PE Cables

Please connect the inverter to the grounding bar through the PE cable to achieve the grounding protection. The PE mark is affixed to the PE terminal. The cross-sectional area of the PE cable is not less than 16mm² (copper wire) and the bolt specification is M6.

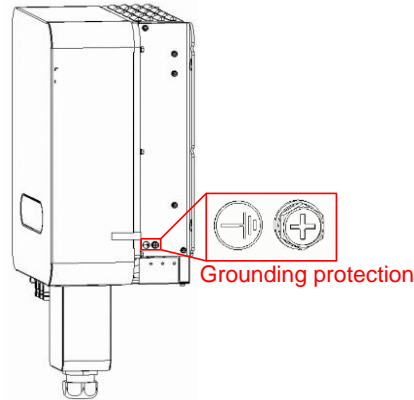

Figure 3-5 Grounding protection

For the grounding of multiple string inverters, please use single-point grounding instead of winding the ground wire into a ring shape as shown below.

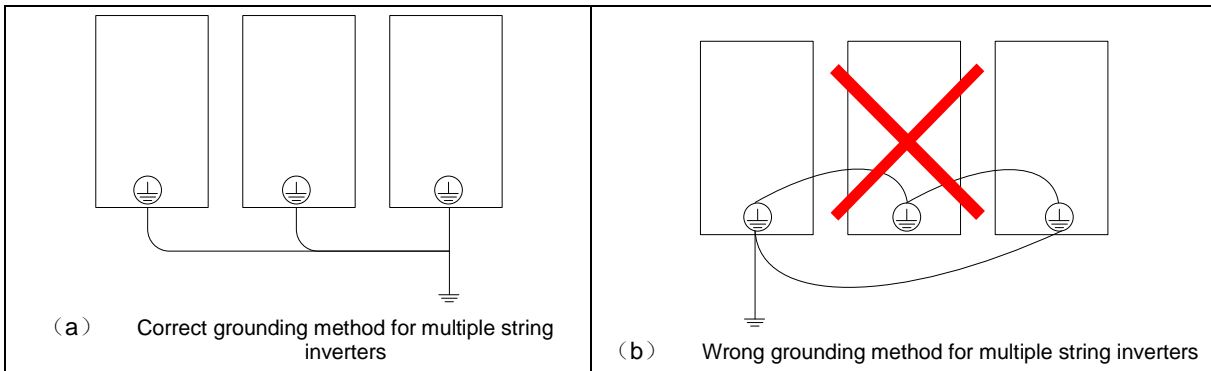

Figure 3-6 PE connection of multiple string inverters

3.6.6 Connecting AC Output Cables

➤ Matters needing attention

- An independent three-phase circuit breaker must be configured outside the AC side of each inverter to ensure reliable disconnection of the inverter from the grid. And the circuit breaker specifications should meet the technical requirements.
- It is forbidden for multiple inverters to share one circuit breaker.
- It is forbidden to connect the load between the inverter and the circuit breaker.
- Users should prepare cables with appropriate cross-sectional area according to different models (please refer to "**3.6.2 Cable Selection**" for more details).

➤ Operation steps

- (1) Remove the cable protection cover, and then unscrew the locking cap of the gland.
- (2) Pass four 10mm² cables through the locking cap and gland, and then connect them to A, B, C, and N of the AC wiring terminal block in turn. Twist the shielding layer of the AC cable into a bundle and connect it to the PE. The following figure takes the 30KTL as an example. For other models, please refer to the actual situation.
- (3) Install the cable protection cover, and then tighten the gland.

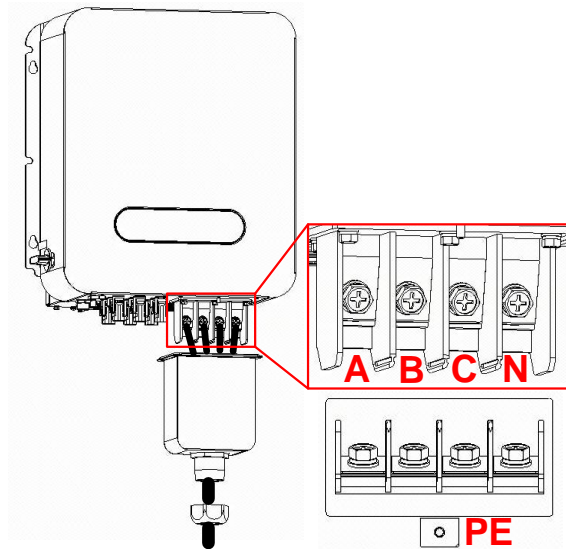

Figure 3-7 AC side cable connection

3.6.7 Connecting Communication Cables

➤ Selection of communication method

The inverter supports zero export communication and RS485 communication.

➤ Connecting the cables

Connect RS485 cables

- 1) Take out the zero export communication terminal from the accessories and then insert the communication cable whose terminal has been crimped and reinforce them with bolts.

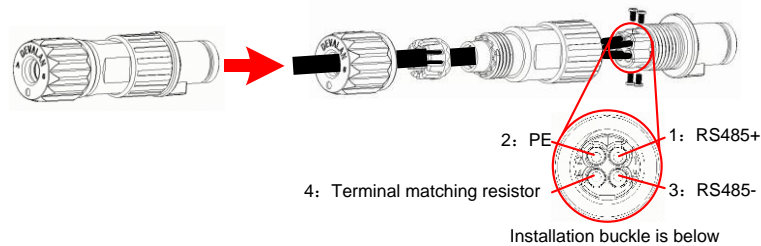



Figure 3-8 Connect cables to the terminal

 Note: If the communication distance exceeds 300m or the field communication quality is poor, the terminal matching resistors of the inverter shall be short-circuited by short-circuiting the PIN1 and PIN4 of the inverter's communication terminal.

- 2) After reassembling the communication terminal, insert it into the zero export communication interface and make sure that the connection is reliable.

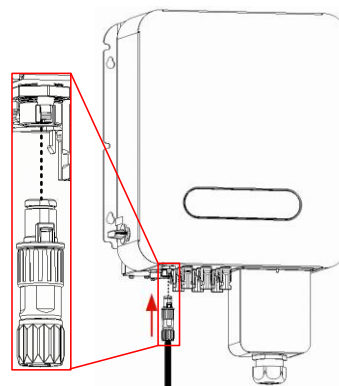

Figure 3-9 Connect the terminal to the inverter

GPRS communication module connection

Connect the GPRS module configured in the delivery accessories to the 4-pin terminal of the inverter, and make sure that the connection is reliable.

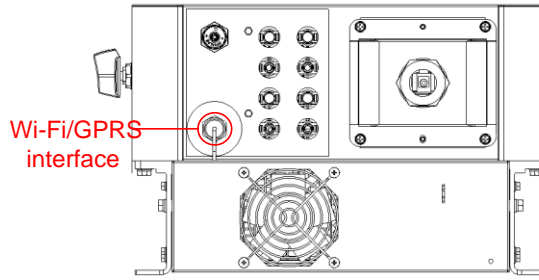

Figure 3-10 Location of the Wi-Fi/GPRS interface

3.6.8 Connecting DC Input Cables

In order to make full use of the DC input power, the PV strings of the same input MPPT should be identical in structure, including the same model, the same number of panels, the same tilt angle, and the same azimuth.



DANGER

1. When the sun shines on the battery panel, it will generate voltage which may cause life-threatening dangers. Therefore, if the DC input line is connected under light conditions, you need to ensure that the input line is not charged (you can cover the panel with an opaque cloth and then proceed operating).
2. Before connecting the input cable, make sure that the DC side voltage is within the safe voltage range which is within 60VDC, and the DC switch is in the "OFF" state, otherwise the high voltage generated may cause a shock hazard.
3. When the inverter is running in the grid, it is forbidden to perform maintenance operations on the DC input cable, otherwise it will cause electric shock hazard.
4. If you want to remove the positive and negative connectors, make sure that DC switch has been placed in the "OFF" state and there is no current output from the PV branch.



WARNING

- Please ensure that the following conditions are met, otherwise it may cause a fire hazard.
- Each serially connected component of the string is of the same specification and model.
 - The maximum opening voltage of each PV string cannot be greater than 1100VDC under any circumstances.
 - The maximum short-circuit current of each PV string should not exceed 30A under any conditions.
 - Ensure that the polarity input on the DC input side is correct, that is, the positive pole of the PV module is connected to the positive pole of the DC input terminal of the inverter, and the negative pole is connected to the negative pole of the DC input terminal of the inverter.

➤ Precautions for grounding the PV string

In the power grid connected to the inverter (such as the low-voltage distribution grid), if the neutral cable is connected to the PE cable, the positive or negative pole of the PV string is prohibited from being grounded, otherwise the inverter cannot work normally.

➤ Steps of crimping MC4 terminal

The input cable needs to be crimped into the MC4 terminal for connection to the string inverter PV+/PV- terminals. Before operation, make sure that **3.6.4 Preparation before Operation** has been completed.

1. Ensure that the positive and negative poles of the input cable are determined and identified.
-  Note: Please do not judge the positive and negative poles according to the cable color in this manual. Be sure to take the actual measurement as the standard.
2. Strip the wire with a wire stripper.

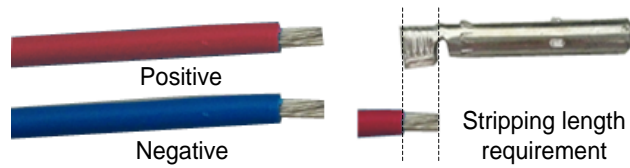

Figure 3-11 Strip wire

3. According to the correct polarity, crimp the cable to the corresponding core.

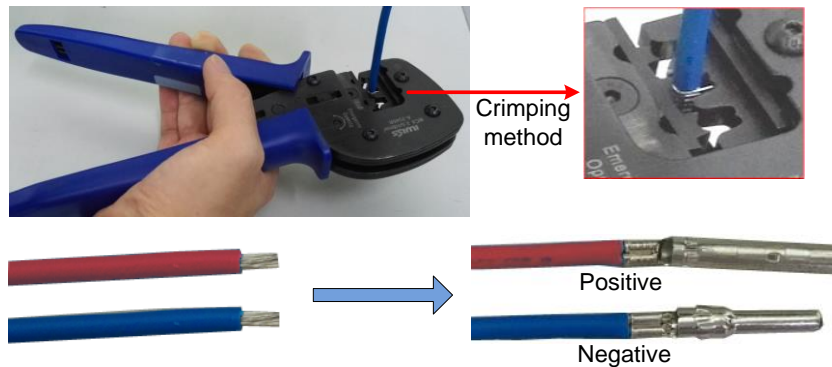

Figure 3-12 Crimp terminals

4. Insert the core into the male and female ends of the MC4 connector according to the correct polarity, and tighten the connector back cover.

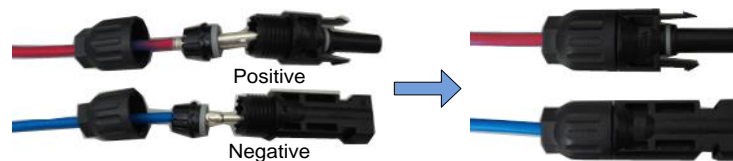

Figure 3-13 Assemble the connector

➤ Insert MC4 terminal

Insert the positive and negative connectors into the positive and negative poles of the DC input terminal respectively until you hear a “click”, which indicates that the terminal is stuck in place.

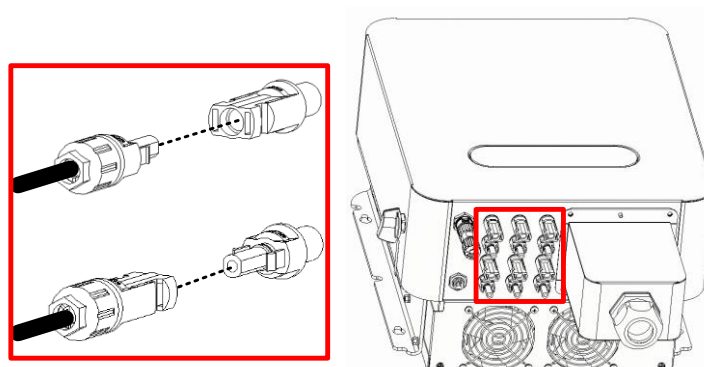

Figure 3-14 Connect DC terminals



Please use the MC4 terminals configured in the delivery accessories of the inverter. Device damage due to incompatible MC4 terminals is not covered by the warranty.

After the cable connection of the string inverter is completed, check if there is a gap at the cable gland. If there is, use fireproof mud to block the gap. If there are unconnected input terminals, seal them well.

--End of the chapter--

4 Commissioning Guide

4.1 Checking before Power-On



- Before powering on the inverter, please read "1 Safety Precautions" carefully and do a detailed check according to the table below.
- Before operating or maintaining the internal metal parts, please use multimeter to measure their voltage to the enclosure (protective earthing) in order to avoid any danger.

After the inverter is installed, the following items need to be checked carefully before power on.

Mechanical inspection

- Please read "1 Safety Precautions" carefully.
- Ensure that the environmental safety of the string inverter.
- Check if there are any foreign objects left inside and on the top of the string inverter cabinet.
- Ensure that the string inverter has enough space reserved around for maintenance and heat dissipation.
- The cables are marked clearly and correctly.
- Check if there any condensation inside the string inverter. If there is, remove it with heating tools.
- Ensure that all wiring screws are tightened according to torque requirements.
- Ensure RS485 wiring is correct and reliable.
- Make sure there is no gap between the input terminal and the cable gland.

Electrical inspection

- Ensure that the connection of the string inverter is reliable and the polarity is correct.
- The power cables and signal cables are all in conformity with the electrical safety regulations.
- Uses of terminals for signal cables and power cables are correct.
- The isolation area and warning signs have been set up around the string inverter to prevent others from misoperation or proximity.

4.2 Powering on the System

After the electrical connection is completed, the inverter can be powered on.

Step 1: Set the DC SWITCH of the inverter to the "ON" state.

Step 2: Close the AC circuit breaker between the inverter and the power grid.

After performing the above steps, if the system has no faults and meets the startup requirements, the inverter will start.

4.3 Powering off the System

➤ Precautions

- After the inverter is powered off, there will be residual electricity and residual heat on the enclosure, which may cause electric shock or burns. Therefore, please wait at least 5 minutes before you operate the inverter.
- When powering off the system, please follow the operation instructions and safety regulations in this chapter.

Step 1: Issue the shutdown command to the inverter through the data collector or near-end APP software.

Step 2: Disconnect the AC circuit breaker between the inverter and the power grid.

Step 3: Set the DC SWITCH of the inverter to the "OFF" state.

--End of the chapter--

5 Maintenance and Troubleshooting

5.1 Maintenance Items and Cycles

 DANGER	
1.	Please read 1 Safety Precautions carefully before maintenance, and use a multimeter and other relevant instruments to detect the voltage between the metal parts that need to be or maybe touched and the grounding copper bars so as to avoid electric shock.
2.	During maintenance, please pay attention to the warning labels of the string inverter to avoid personal injury due to high voltage.
3.	During maintenance, please make sure that the DC switch is in off state, and the circuit breaker between the inverter and the grid is disconnected.
4.	After the maintenance, close the DC input switch of the inverter and the circuit breaker between the inverter and the grid.

String inverters need to be regularly maintained. Common maintenance items and cycles are shown in the table below.

Table 5-1 Maintenance items and cycles of the string inverters

Parts	Item	Description	Solutions	Maintenance Cycle
Overall inspection	Appearance	Observe whether the inverter appearance is damaged or deformed.	Please replace it in time when it is serious.	Once every six months to one year
	System cleaning	Check if there are dusts and foreign matters on the surface of the inverter.	Clean up the foreign matters and dusts.	
		The heat sink is covered with dust and dirt.	Remove occlusion and clean dusts	
System running	Operating state	Check if there is any abnormal noise while the inverter is running.	If the problem is serious, please replace it in time.	Once every six months to one year
	Operating parameters	When the inverter is running, check whether the parameters are set correctly.	Troubleshoot abnormal settings	
Connection parts	Fall off or loose	Check if the cable connection is disconnected or loose.	Tighten connections as specified	Once every six months to one year
	Damage	Check if there is any damage on the cable. Especially check the surface of the cable that is in contact with the metal surface for traces.	If the problem is serious, please replace it in time.	
	Terminal	Check if the waterproof covers of the unused RS485, RJ45 or other terminals are locked tightly	Ensure that they are sealed well.	

 Note: Before wiping the heat sink, power off the inverter normally and disconnect the circuit breaker between the inverter and the grid, and then set the DC switch of the inverter into the OFF state. After powering off, wait at least 5 minutes before wiping the heat sink so as to avoid accidents.

5.2 Troubleshooting

➤ Boost Side

Fault word	ID	Fault/alarm name	Fault/alarm cause	Troubleshooting
Fault word 1	0	Auxiliary power fault	The voltage of the $\pm 12V$ auxiliary power is abnormal.	1. Check whether it can work normally after reset. 2. If it occurs frequently, please contact the Hopewind technician.
	2	Output hardware overvoltage	The output voltage exceeds the protection threshold specified by the hardware.	1. Check whether it can work normally after reset. 2. If it occurs frequently, please contact the Hopewind technician.
	3	Hardware overcurrent (secondary)	The MPPT inductor current is too large.	1. Check whether it can work normally after reset. 2. If it occurs frequently, please contact the Hopewind technician.
	4	MPPT1 hardware overcurrent	MPPT1 experiences overcurrent and reaches the hardware CBC time.	1. Check whether it can work normally after reset. 2. If it occurs frequently, please contact the Hopewind technician.
	5	MPPT2 hardware overcurrent	MPPT2 experiences overcurrent and reaches the hardware CBC time.	1. Check whether it can work normally after reset. 2. If it occurs frequently, please contact the Hopewind technician.
	6	MPPT3 hardware overcurrent	MPPT3 experiences overcurrent and reaches the hardware CBC time.	1. Check whether it can work normally after reset. 2. If it occurs frequently, please contact the Hopewind technician.
	7	MPPT4 hardware overcurrent	MPPT4 experiences overcurrent and reaches the hardware CBC time.	1. Check whether it can work normally after reset. 2. If it occurs frequently, please contact the Hopewind technician.
Fault word 2	2	EEPROM parameters back to default values	EEPROM read/write fails.	Fault reset or power off
	3	Historical fault storage failed	Historical faults fail to be stored.	Fault reset or power off
	12	Reverse input polarity	The input polarity is reversely connected.	Check whether the polarity of the connection is reversed.
	13	Abnormal insulation of positive busbar to ground	The insulation impedance of the positive busbar to ground is abnormal.	Check whether the positive busbar has grounding fault.
	14	Abnormal insulation of negative busbar to ground	The insulation impedance of the negative busbar to ground is abnormal.	Check whether the negative busbar has grounding fault.
Alarm word 1	0	SPD alarm	The SPD is faulty or is in a wrong state.	1. Check whether it can work normally after reset. 2. If it occurs frequently, please contact the Hopewind technician.
	6	Boost-side open circuit alarm	An open circuit occurs inside the boost.	Please contact the Hopewind technician.
	7	Boost-side short circuit alarm	A short circuit occurs inside the boost.	Please contact the Hopewind technician.
	8	Battery string abnormal alarm	Battery string is abnormal.	1. Check whether the battery string configuration is abnormal. 2. Check whether the access of the battery board is abnormal. 3. Check whether the current sampling of the battery string is abnormal.

Fault word	ID	Fault/alarm name	Fault/alarm cause	Troubleshooting
	9	Positive busbar to ground insulation alarm	The insulation impedance of the positive busbar to ground is abnormal.	Find out the cause of abnormal impedance.
	10	Negative busbar to ground insulation alarm	The insulation impedance of the negative busbar to ground is abnormal.	Find out the cause of abnormal impedance.

➤ Inverter Side

Fault word	ID	Fault/alarm name	Fault/alarm cause	Troubleshooting
System fault status word	0	RAM self-test failed	RAM chip read/write fails.	1. Check whether it can work normally after reset. 2. If it occurs frequently, please contact the Hopewind technician.
	1	EEPROM parameters back to default values	The EEPROM parameter list is newly added and the code is re-upgraded. The default value after initialization is different from that in EEPROM.	1. Check whether it can work normally after reset. 2. If it occurs frequently, please contact the Hopewind technician.
	2	EEPROM read/write failed	EEPROM read/write fails.	1. Check whether it can work normally after reset. 2. If it occurs frequently, please contact the Hopewind technician.
	3	FPGA version mismatch	FPGA version does not match with that of DSP	1. Check whether it can work normally after reset. 2. If it occurs frequently, please contact the Hopewind technician.
	4	Historical faults storage failed	Historical faults fail to be stored.	1. Check whether it can work normally after reset. 2. If it occurs frequently, please contact the Hopewind technician.
	5	Internal communication fault	Internal communication fails.	1. Check whether it can work normally after reset. 2. If it occurs frequently, please contact the Hopewind technician.
Hardware fault status word	0	Hardware overcurrent (secondary)	The current peak of inductor exceeds the hardware protection threshold.	1. Check whether it can work normally after reset. 2. If it occurs frequently, please contact the Hopewind technician.
	3	A-phase hardware overcurrent	A-phase inductor current triggers CBC protection.	1. Check whether it can work normally after reset. 2. If it occurs frequently, please contact the Hopewind technician.
	4	B-phase hardware overcurrent	B-phase inductor current triggers CBC protection.	1. Check whether it can work normally after reset. 2. If it occurs frequently, please contact the Hopewind technician.
	5	C-phase hardware overcurrent	C-phase inductor current triggers CBC protection.	1. Check whether it can work normally after reset. 2. If it occurs frequently, please contact the Hopewind technician.
	6	Busbar hardware overvoltage	The bus voltage exceeds the hardware overvoltage threshold.	1. Check whether it can work normally after reset. 2. If it occurs frequently, please contact the Hopewind technician.

Fault word	ID	Fault/alarm name	Fault/alarm cause	Troubleshooting
	7	Busbar neutral-point overvoltage	The bus neutral-point voltage exceeds the hardware overvoltage threshold.	1. Check whether it can work normally after reset. 2. If it occurs frequently, please contact the Hopewind technician.
Grid fault status word	0	Uab overvoltage	Uab exceeds the overvoltage protection threshold specified by the system.	1. Confirm whether there is a fault such as a box-type transformer tripped on the AC side at the fault time. 2. Confirm whether the inverter has HVRT.
	1	Ubc overvoltage	Ubc exceeds the overvoltage protection threshold specified by the system.	1. Confirm whether there is a fault such as a box-type transformer tripped on the AC side at the fault time. 2. Confirm whether the inverter has HVRT.
	2	Uca overvoltage	Uca exceeds the overvoltage protection threshold specified by the system.	1. Confirm whether there is a fault such as a box-type transformer tripped on the AC side at the fault time. 2. Confirm whether the inverter has HVRT.
	3	Uab undervoltage	Uab is lower than the undervoltage protection threshold specified by the system.	Confirm whether the phase loss of the inverter occurs and whether the box-type transformer contacts are suitable, etc.
	4	Ubc undervoltage	Ubc is lower than the undervoltage protection threshold specified by the system.	Confirm whether the phase loss of the inverter occurs and whether the box-type transformer contacts are suitable, etc.
	5	Uca undervoltage	Uca is lower than the undervoltage protection threshold specified by the system.	Confirm whether the phase loss of the inverter occurs and whether the box-type transformer contacts are suitable, etc.
	6	Grid abnormal	The grid frequency or voltage exceeds the system allowed range.	1. Confirm whether the access to the grid is the nominal grid of the inverter. 2. Confirm whether the grid is connected.
	7	Grid voltage imbalance threshold exceeded	The grid voltage imbalance exceeds the system threshold.	Check whether the grid is abnormal.
	8	Grid overfrequency	The grid frequency exceeds the overfrequency protection threshold specified by the system.	1. Confirm whether the box-type transformer tripping and other faults occur on the AC side of the inverter through fault recording and event recording. 2. Confirm whether the frequency range and the time setting is reasonable.
	9	Grid underfrequency	The grid frequency is lower than the underfrequency protection threshold specified by the system.	1. Confirm whether the box-type transformer tripping and other faults occur on the AC side of the inverter through fault recording and event recording. 2. Confirm whether the frequency range and the time setting is reasonable.
	11	Anti-islanding protection	The grid experiences voltage loss.	Detect the causes of grid voltage loss, such as box-type transformer tripping, etc.

Fault word	ID	Fault/alarm name	Fault/alarm cause	Troubleshooting
	13	Grid voltage abnormal	The grid experiences voltage sudden change.	Check if the grid is normal.
	14	LVRT protection	The grid voltage exceeds the LVRT protection threshold.	Check if the grid is normal.
	15	HVRT protection	The grid voltage exceeds the HVRT protection threshold.	Check if the grid is normal.
Inverter fault status word	0	Module A-phase software overcurrent	The effective value of the inductor current exceeds the protection threshold.	Reset the fault.
	1	Module B-phase software overcurrent	The effective value of the inductor current exceeds the protection threshold.	Reset the fault.
	2	Module C-phase software overcurrent	The effective value of the inductor current exceeds the protection threshold.	Reset the fault.
	3	Module current imbalance	Three-phase current imbalance exceeds the threshold.	Reset the fault.
	5	Module overtemperature	The temperature of the radiator is higher than the protection threshold.	Check whether the spoiler fan is normal.
	6	Internal overtemperature	The ambient temperature is higher than the protection temperature.	Check whether the spoiler fan is normal.
	9	Residual current abnormal	The residual current exceeds the threshold.	1. If it happens accidentally, it may be caused by the accidental abnormality of the external line. After the fault is cleared, it will resume work without manual intervention. 2. If it occurs frequently or cannot be recovered for a long time, please check whether the ground impedance of the PV string is too low.
Bus fault word status	1	Bus short circuit	The bus voltage dip exceeds the threshold.	1. Check whether it can work normally after reset. 2. If it occurs frequently, please contact the Hopewind technician.
	5	Bus overvoltage	The bus voltage exceeds the specified threshold.	1. Check whether it can work normally after reset. 2. If it occurs frequently, please contact the Hopewind technician.
	6	Bus undervoltage	The bus voltage is lower than the specified threshold.	1. Check whether it can work normally after reset. 2. If it occurs frequently, please contact the Hopewind technician.
	7	Bus voltage imbalance	The voltage imbalance of the positive and negative busbars exceeds the specified threshold.	1. Check whether it can work normally after reset. 2. If it occurs frequently, please contact the Hopewind technician.
	8	High DC input voltage	The DC input voltage exceeds the specified threshold.	1. Check whether the components are over matched. 2. Check whether the input voltage detection circuit is normal.
	9	Low DC input voltage	The DC input voltage is lower than the specified threshold.	Check whether the switch is disconnected.

Fault word	ID	Fault/alarm name	Fault/alarm cause	Troubleshooting
Other	0	AC relay fault	The relay status is wrong.	1. Check whether it can work normally after reset. 2. If it occurs frequently, please contact the Hopewind technician.
	3	AC SPD alarm	The AC side SPD feedback status is wrong.	1. Check whether it can work normally after reset. 2. If it occurs frequently, please contact the Hopewind technician.
	4	Internal fan fault	Fan fails or the feedback signal is abnormal.	1. Check whether it can work normally after reset. 2. If it occurs frequently, please contact the Hopewind technician.
	5	External fan fault	Fan fails or the feedback signal is abnormal.	1. Check whether it can work normally after reset. 2. If it occurs frequently, please contact the Hopewind technician.

--End of the chapter--

6 Inverter Disposal

6.1 Removing the Inverter

Before operating, make sure that the circuit breaker between the inverter and the grid is disconnected, and the DC switch is placed in the "OFF" state.

- 1) Disconnect all electrical connections to the inverter, including the AC output cable, RS485 communication cable, DC input cable and PE cable.
- 2) Remove the inverter from the mounting plate.

6.2 Replacing the Inverter

After disassembling the old inverter, if it is necessary to replace it with a new one, please follow the operation instructions in Chapter 3 and 4.

6.3 Packing the Inverter

- If you still keep the original package of the inverter, please put it into the original package and firmly seal it with tapes.
- If you can't find the original package, please use a hard carton suitable for the weight and dimension of the inverter to firmly package it.

6.4 Disposing of the Inverter

When the service life of the inverter expires or the inverter is replaced due to failure, it can be disposed according to the applicable electrical waste disposal laws of the place where the inverter is installed, or it can be handed over to Hopewind customer service personnel.

--End of the chapter--

Appendix

Warranty

If the product has any fault during the warranty period, we will provide cost-free repair or replacement service.

Any faults arising from the following reasons shall be out of the warranty:

- Users dismantle the product arbitrarily or maintain it in the wrong way;
- Out of the warranty period;
- Use the product out of the application scope stipulated in related international standard;
- Fail to install and operate the product according to the user manual;
- Use the product in improper environment;
- Use non-standard or those components/software not provided by our company;
- Damaged due to the failure of external devices;
- Any accidental damage arising from personal modification or maintenance by users.

If you need to repair the inverter due to above reasons, we will offer paid repair service after it is determined by our service department. If you need to repair or modify this product, please contact our company in advance.

Contact Us



Shenzhen Hopewind Electric Co., Ltd.

Address: Building 11, Second Industrial Zone, Guanlong Village, Xili Street, Nanshan District, Shenzhen, P.R.China

Website: www.hopewind.com

E-mail: Globalservice@hopewind.com



 Building 11, Second Industrial Zone, Guanlong Village,
Xili Street, Nanshan District, Shenzhen, P.R.China
 Globalservice@hopewind.com
 www.hopewind.com

Copyright © 2024 Shenzhen Hopewind Electric Co., Ltd. All rights reserved.